

QCTHSA

RETRACTABLE HEAVY DUTY QUARTER-TURN CLAMPS



QCTHSA0825-20
(Plastic Knob)
(OFF position)



QCTHSA0825-20S
(Metal Knob)
(ON position)

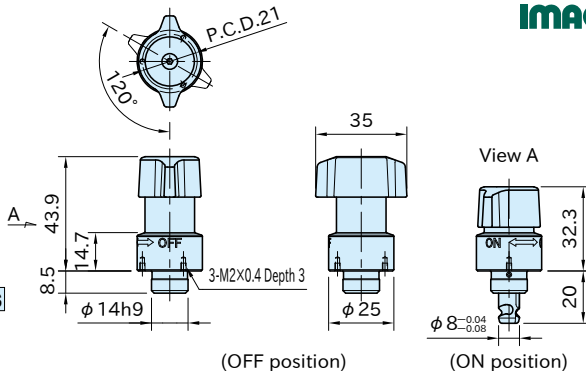

(OFF position) (ON position)
QCTHSA0825-20 **QCTHSA0825-20S**



QCTHSA0834-20
(Plastic Knob)
(OFF position)



QCTHSA0834-20S
(Metal Knob)
(ON position)

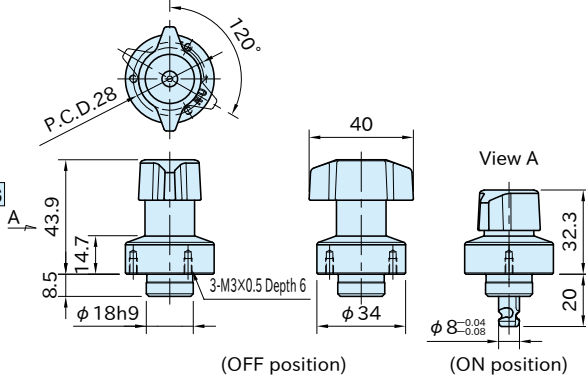

(OFF position) (ON position)
QCTHSA0834-20 **QCTHSA0834-20S**

★Key Point

No interference by retractable shank

Type	Body	Shank	Pin	Knob	Spring A	Spring B
QCTHSA	SUS303 stainless steel	SKS3 steel	SUS420J2 stainless steel	Polyamide (glass-fiber reinforced)	Equivalent to SWOSC-V steel	SUS304WPB stainless steel
QCTHSA-S		Electroless nickel plated Quenched and tempered	Quenched and tempered	Black SCS13 stainless steel (Equivalent to SUS304)		

Part Number	Proper Plate Thickness	Clamping Force (N)	Holding Force (N)**	Weight (g)	Proper Locking Receptacle
QCTHSA0825-20	6~20 *)	250	250	76	QCTHSA0834-B
QCTHSA0825-20S				104	
QCTHSA0834-20		400	400	130	
QCTHSA0834-20S				160	

*) Spacer **QCASP** is required for thinner plate than 9mm.

**) Exceeding the holding force creates a gap of greater than 0.1mm between plates.

QCTHS-B LOCKING RECEPTACLE



Supplied With

- **QCTHSA** **QCTHSA-S** 0825-20:
3 of socket-head cap screws (stainless steel) M2X0.4-8L
- **QCTHSA** **QCTHSA-S** 0834-20:
3 of socket-head cap screws (stainless steel) M3X0.5-10L

Feature

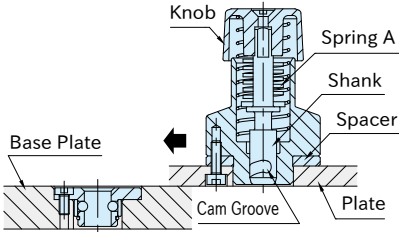

The shank retracts at the unclamping position to enable operations without interference with the base plate.

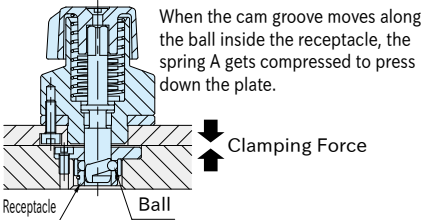

When the cam groove moves along the ball inside the receptacle, the spring A gets compressed to press down the plate.

Clamping Force

Mechanical Strength

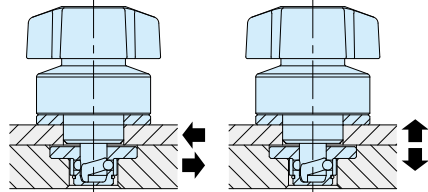

Shear Strength

Tensile Strength

Part Number	Heatresistant Temperature (°C)	Shear Strength(N)	Tensile Strength(N)
QCTHSA0825-20	130	3000	1600
QCTHSA0825-20S	180		
QCTHSA0834-20	130	3000	1600
QCTHSA0834-20S	180		

Shear and tensile strength is allowable load and the fastener could break when it receives bigger load.

How To Use

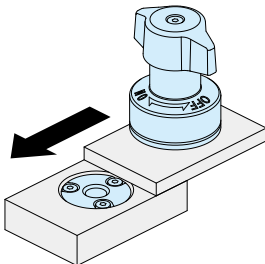

1. Ensure that the knob is positioned at the "OFF" mark.

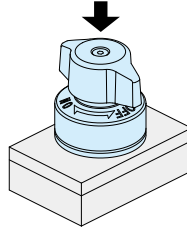

2. Insert the clamp pressing the knob.

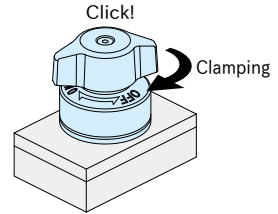

3. Turn the knob to the "ON" mark for clamping. The knob clicks when clamped. Turning the knob to the "OFF" position, the shank returns automatically to the unclamping position by the spring.

Application Example

Die Changing

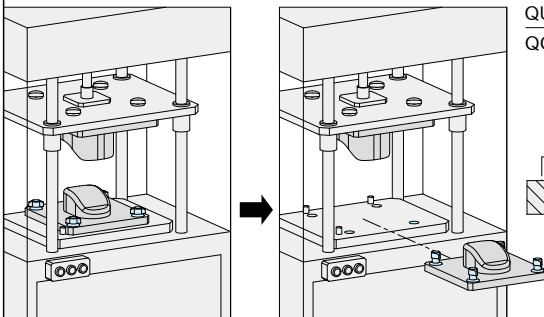

RETRACTABLE HEAVY DUTY QUARTER-TURN CLAMP QCTHSA0834-20

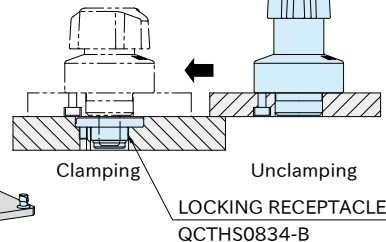

Continuing on Next Page

Application Example

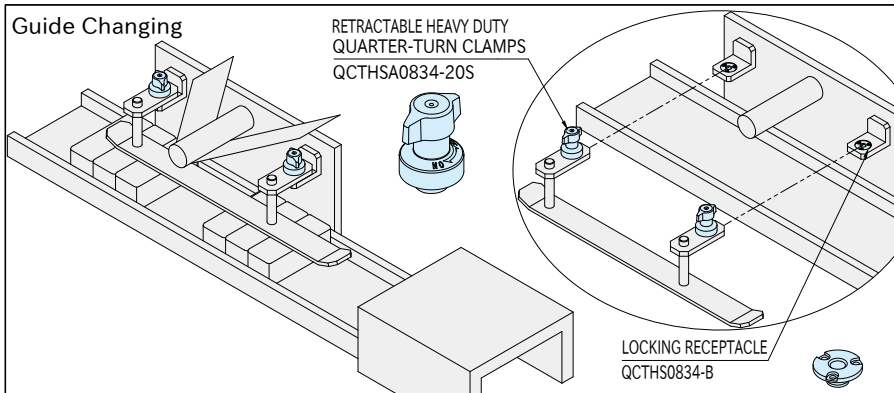

Accuracy

■ Machining Accuracy

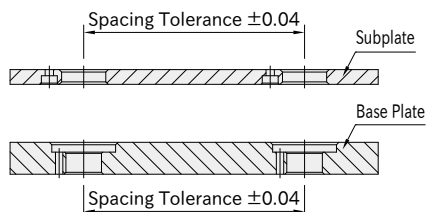

Spacing tolerance on both the subplate and the base plate should be ± 0.04 .

■ Repeatability

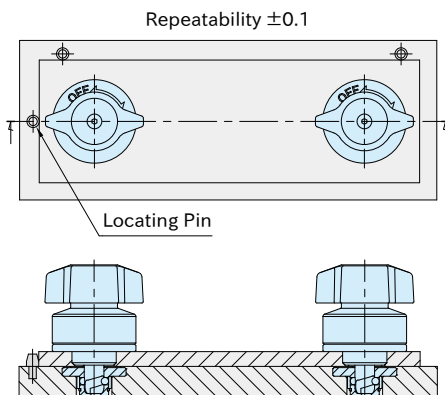

For higher accurate locating, use locating pins.

Reference

"How To Install Receptacle" of [QCTHS-B](#) LOCKING RECEPTACLE.

QCTHSA

SPACERS

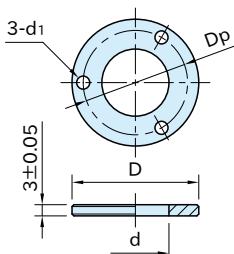

Body
SUS303 stainless steel

Part Number	D	d ($^{+0.1}$ / 0)	Dp	d ₁	Weight (g)
QCTHSA25-03-SUS	25	14	21	2.3	7
QCTHSA34-03-SUS	34	18	28	3.5	14

How To Install

QCTHSA0825-20

QCTHSA0825-20S

For 9mm plate

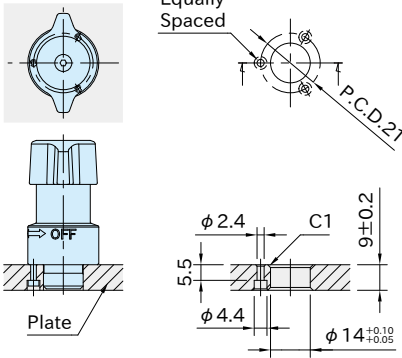

For over 9mm to 20mm plate

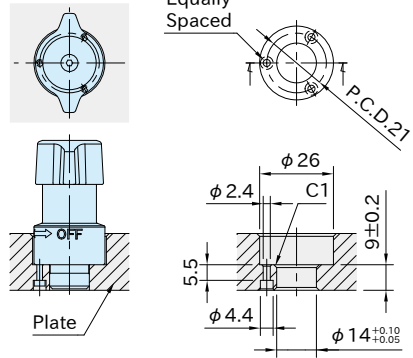

For 6mm plate

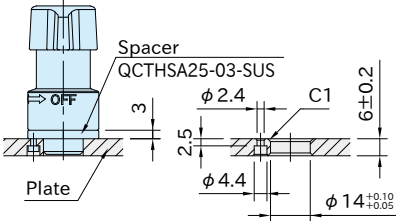

For over 6mm to under 9mm plate

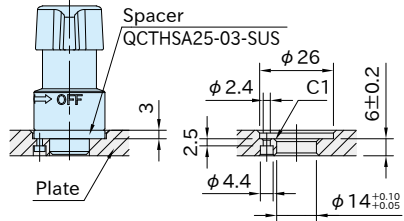

QCTHSA0834-20

QCTHSA0834-20S

For 9mm plate

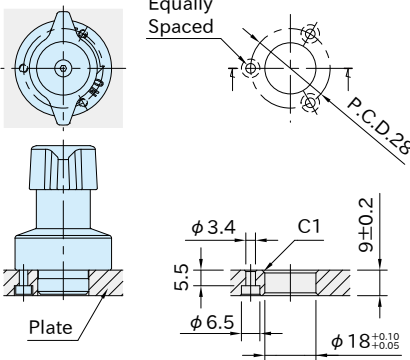

For over 9mm to 20mm plate

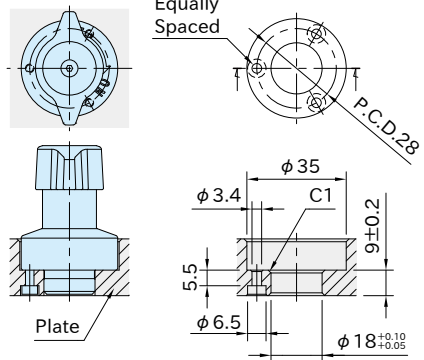

For 6mm plate

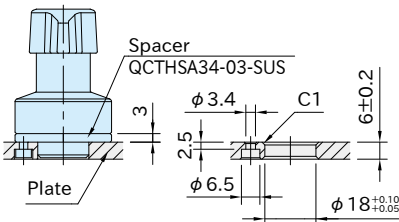

For over 6mm to under 9mm plate

