

# QCBA / QCBAS BALL-LOCK CLAMPING RECEPTACLES



Heat resistance: 180°C



**QCBA0816**  
(Standard)

**QCBAS0820**  
(Safety Lock)

Type	Body/Collar	Balls	Coiled Spring	Locking Knob
<b>QCBA0816</b>	S45C steel	SUS440C stainless steel	SUS304WPB	—
<b>QCBAS0820</b>	Electroless nickel plated	Quenched and tempered	stainless steel	S45C steel Electroless nickel plated

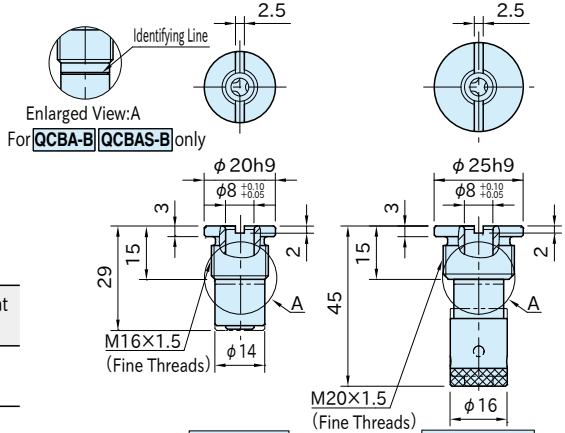

## QCBA0816 (Standard)

Part Number	Clamping Force (N)	Weight (g)
<b>QCBA0816A</b>	7	30
<b>QCBA0816B</b>	15	

## QCBAS0820 (Safety Lock)

Part Number	Clamping Force (N)	Weight (g)
<b>QCBAS0820A</b>	7	65
<b>QCBAS0820B</b>	15	

**QCBA0816**  
(Standard)

**QCBAS0820**  
(Safety Lock)

Order Separately Nut (Stainless Steel)

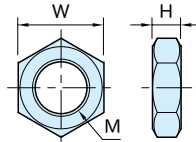

Part Number	M (Fine Threads)	H	W	Ball-Lock Clamping Receptacles
<b>NDX16-NUT-SUS</b>	M16×1.5	8	24	QCBA0816
<b>NDX20-NUT-SUS</b>	M20×1.5	10	30	QCBAS0820

Order Separately Installation Wrench



Part Number  
**PW16**

# QCBA-M

# BALL-LOCK CLAMPING PINS



Heat resistance: 180°C

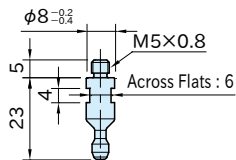

Body
S45C steel Quenched and tempered Electroless nickel plated

Part Number	Weight (g)
<b>QCBA0816-M5</b>	7

## Feature

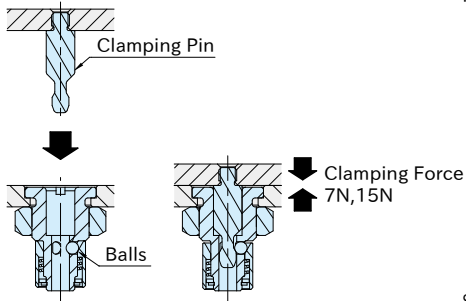

The 3 balls pull in the clamping pin.

## Mechanical Strength

Heatresistant Temperature 180°C

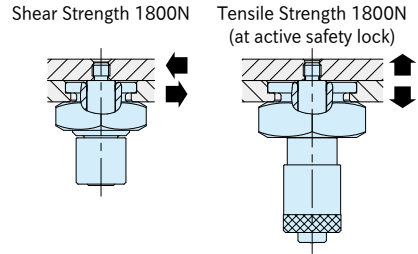

Shear and tensile strength is allowable load and the fastener could break when it receives bigger load.

When the fastener receives tensile load that is bigger than its clamping force, there is a gap between the plates.

## How To Operate Safety Lock

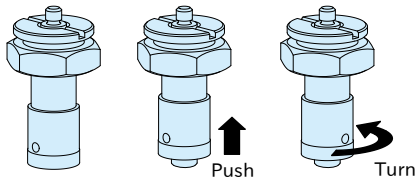

Turn in the arrowhead direction pushing the locking knob.  
Note: To release the safety lock, follow the steps back.

## How To Check Safety Lock

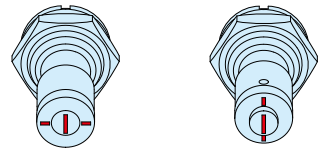

When the mark lines on the end of the locking knob are aligned, the safety lock is active.

## Application Example

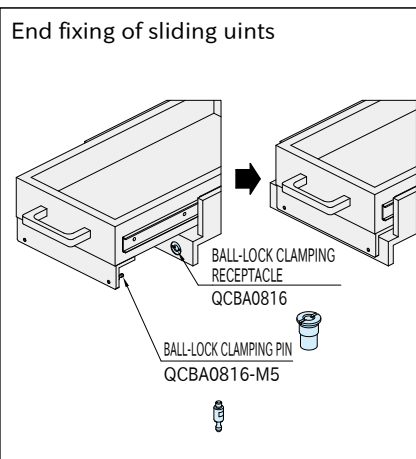
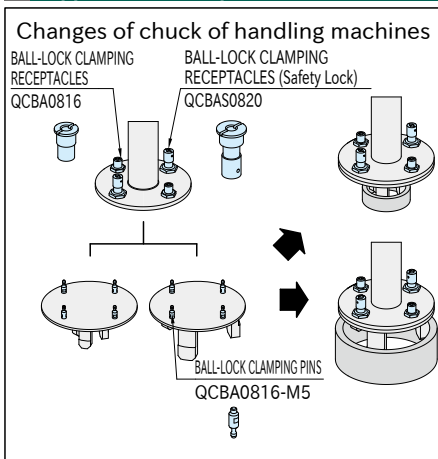

Continuing to next page

## How To Install (Standard)

For installation in a subplate of thickness ranging from 6mm to 10mm, use a nut for fastening.

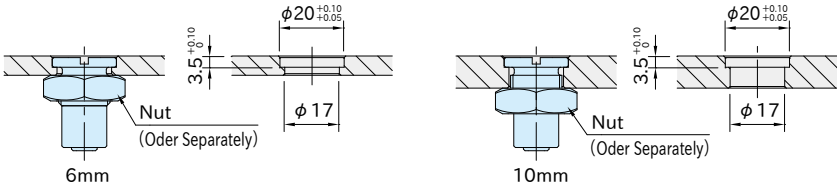

For installation in a subplate of thickness over 10mm, use a screw-in method.

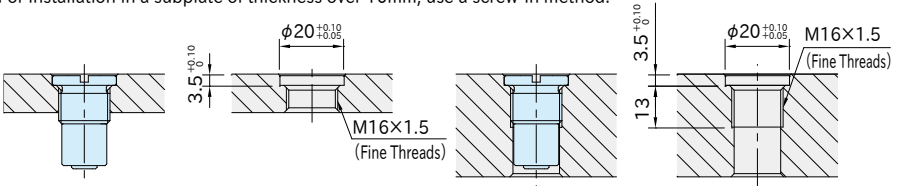

Installation in a subplate

Installation in a block

## How To Install (Safety Lock)

For installation in a subplate of thickness ranging from 6mm to 10mm, use a nut for fastening.

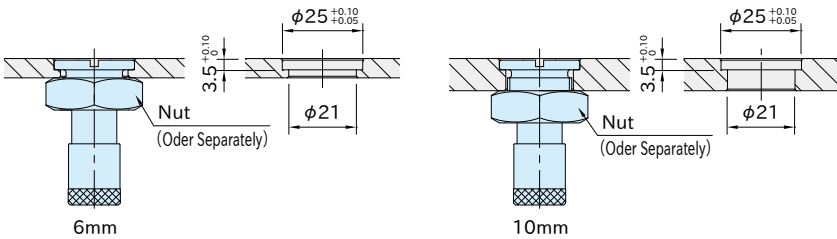

6mm

10mm

For installation in a subplate of thickness ranging from 10mm to 32mm, use a screw-in method.

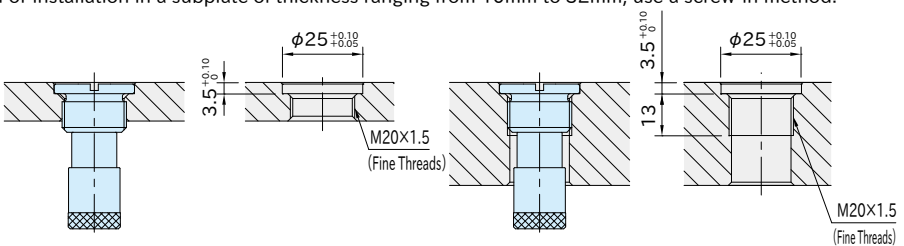

Installation in a subplate

Installation in a block

## How To Install (Ball-Lock Clamping Pins)

Plate thickness should be 6mm or more.

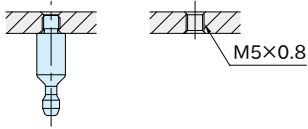

## Accuracy

### ■ Machining Accuracy

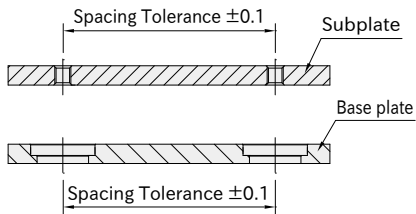

Spacing tolerance on both the subplate and the base plate should be  $\pm 0.1$ .

### ■ Repeatability

Repeatability  $\pm 0.25$

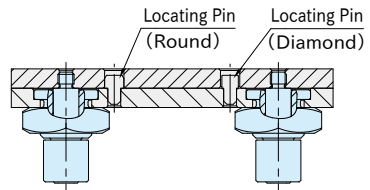

For higher accurate locating, use locating pins.